

CLC018

8 x 8 Digital Crosspoint Switch, 1.485 Gbps

General Description

The CLC018 is a fully differential 8x8 digital crosspoint switch capable of operating at data rates exceeding 1.485 Gbps per channel. Its non-blocking architecture utilizes eight independent 8:1 multiplexers to allow each output to be independently connected to any input and any input to be connected to any or all outputs. Additionally, each output can be individually disabled and set to a high-impedance state. This TRI-STATE feature allows flexible expansion to larger switch array sizes.

Low channel-to-channel crosstalk allows the CLC018 to provide superior all-hostile jitter of 50 ps_{PP}. This excellent signal fidelity along with low power consumption of 850 mW make the CLC018 ideal for digital video switching plus a variety of data communication and telecommunication applications.

The fully differential signal path provides excellent noise immunity, and the I/Os support ECL and PECL logic levels. In addition, the inputs may be driven single-ended or differentially and accept a wide range of common mode levels including the positive supply. Single +5V or -5V supplies or dual +5V supplies are supported. Dual supply mode allows the control signals to be referenced to the positive supply (+5V) while the high-speed I/O remains ECL compatible.

The double row latch architecture utilized in the CLC018 allows switch reprogramming to occur in the background during operation. Activation of the new configuration occurs with a single "configure" pulse. Data integrity and jitter performance on unchanged outputs are maintained during re-configuration. Two reset modes are provided. Broadcast reset results in all outputs being connected to input port D10. TRI-STATE Reset results in all outputs being disabled.

The CLC018 is fabricated on a high-performance BiCMOS process and is available in a 64-lead plastic quad flat pack (PQFP).

Features

- Supports SMPTE 259M, SMPTE 344M, and SMPTE 292M
- Fully differential signal path
- Non-Blocking
- Flexible expansion to larger array sizes with very low power
- Single +5/-5V or dual ±5V operation
- TRI-STATE outputs
- Double row latch architecture
- 64-lead PQFP package

Applications

- Routing switchers
- Production switchers
- Master control switchers
- Telecom/datacom switchers
- Storage Area Network (SAM)
- Packet switching
- ATM SONET

Key Specifications

- High speed: >1.485 Gbps
- Low jitter:
 - <50 ps_{PP} for rates <500 Mbps
 - <100 ps_{PP} for rates <1.485 Gbps
- Low power; 850 mW with all outputs active
- Fast output edge speeds: 250 ps

CLC018 Block Diagram

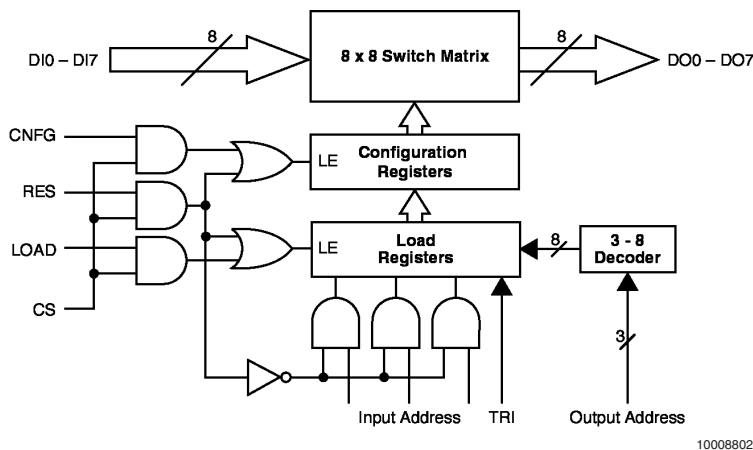

Output Eye Pattern, 1.4Gbps

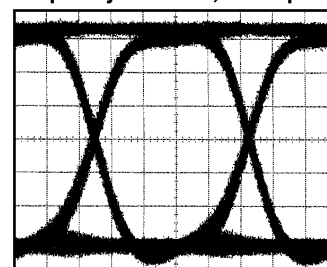

150ps/div

10008801

10008802

Absolute Maximum Ratings (Note 1)

If Military/Aerospace specified devices are required, please contact the National Semiconductor Sales Office/Distributors for availability and specifications.

Supply Voltage ($V_{CC}-V_{EE}$)	-0.3V to +6.0V
V_{LL} Maximum	$V_{CC} +6V$
V_{LL} Minimum	$V_{CC} -0.5V$
Storage Temperature Range	-65°C to +150°C
Lead Temp. (Soldering 4 sec.)	+260°C
ESD Rating	TBD
Package Thermal Resistance	

θ_{JA} 64-Pin PQFP	75°C/W
θ_{JC} 64-Pin PQFP	15°C/W
Reliability Information	
Transistor Count	3000

Recommended Operating Conditions

Supply Voltage ($V_{CC}-V_{EE}$)	4.5V to 5.5V
Operating Temperature	-40°C to +85°C
V_{LL}	V_{CC} or $V_{CC} +5V$

Electrical Characteristics

($V_{CC} = 0V$, $V_{EE} = -5V$, $V_{LL} = 0V$; unless otherwise specified) (Note 4).

Parameter	Conditions	Typ +25°C	Min/Max +25°C	Min/Max -40°C to +85°C	Units
DYNAMIC PERFORMANCE					
Max. Data Rate/Channel (NRZ)	(Note 5)	1.485			Gbps
Channel Jitter	Data Rate <500 Mbps (Note 6)	50			ps _{PP}
	Data Rate <1.485 Gbps (Note 6)	100			ps _{PP}
Propagation Delay (input to output)		0.75			ns
Propagation Delay Match	(Note 7)	±200			ps
Output Rise/Fall Time	(Note 8)	250			ps
Duty Cycle Distortion	(Note 9)	10			ps
CONTROL TIMING: CONFIGURATION					
OA Bus to LOAD ↑ Setup Time (T_1)		15			ns
LOAD ↓ to OA Bus Hold Time (T_2)		0			ns
IA Bus, TRI to LOAD ↓ Setup Time (T_3)		5			ns
LOAD ↓ to IA Bus, TRI Hold Time (T_4)		5			ns
Min Pulse Width: (T_5)					
LOAD		10			ns
CNFG		10			ns
LOAD ↑ to CNFG ↑ Delay (T_6)		0			ns
CNFG ↑ to Valid Delay (T_7)		20			ns
CNFG ↑ to Output TRI-STATE® Delay (T_8)		20			ns
CNFG ↑ to Output Active Delay (T_9)		70			ns
CONTROL TIMING: RESET (Note 11)					
TRI to RES ↑ Setup Time (T_{10})		5			ns
RES ↓ to TRI Hold Time (T_{11})		5			ns
Min Pulse Width: RES (T_{12})		10			ns
RES ↑ to TRI-STATE Mode Delay (T_{13})		20			ns
RES ↑ to Broadcast Mode Delay (T_{14})		70			ns
STATIC PERFORMANCE					
Signal I/O:					
Min Input Swing, Differential	(Note 3)	150	200	200	mV _{PP}
Input Voltage Range Lower Limit		-2			V
Input Voltage Range Upper Limit		0.4			V
Input Bias Current	(Notes 3, 12)	1.5	0.4/3.1	0.3/3.8	μA/output
Output Current	(Note 3)	10.7	8.53/12.80	7.20/14.3	mA

Electrical Characteristics (Continued)

($V_{CC} = 0V$, $V_{EE} = -5V$, $V_{LL} = 0V$; unless otherwise specified) (Note 4).

Parameter	Conditions	Typ +25°C	Min/Max +25°C	Min/Max -40°C to +85°C	Units
Output Voltage Swing	$R_{LOAD} = 75\Omega$	800	640/960	540/1060	mV
Output Voltage Range Lower Limit		-2.5			V
Output Voltage Range Upper Limit		0			V
Control Inputs:					
Input Voltage - HIGH $V_{IH\ min}$	(Note 3)	-1	-0.5	-0.5	V
Input Voltage - LOW $V_{IL\ max}$	(Note 3)	-4	-4.5	-4.5	V
Input Voltage - HIGH $V_{IH\ min}$	$V_{LL} = +5V$ (Note 3)	4	4.5	4.5	V
Input Voltage - LOW $V_{IL\ max}$	$V_{LL} = +5V$ (Note 3)	1	0.5	0.5	V
Input Current - HIGH	$V_{IH} = V_{LL}$ (Note 3)	1	0.2/2.0	0.1/2.5	μA
Input Current - LOW	$V_{IL} = V_{LL} - 5V$ (Note 3)	-100	-200/10	-250/15	μA

MISCELLANEOUS PERFORMANCE

V_{CC} Supply Current	All Outputs Active (Notes 3, 13, 14)	157	127/202	119/217	mA
V_{CC} Supply Current	All Outputs TRI-STATE (Note 3)	7	3/11	2/12	mA
V_{LL} Supply Current	$V_{LL} = 0V$ (Note 3)	2.5	1.7/3.3	1.5/3.5	mA
V_{LL} Supply Current	$V_{LL} = +5V$ (Note 3)	7			mA
Input Capacitance		1.5			pF
Output Capacitance		2			pF

Note 1: "Absolute Maximum Ratings" are those values beyond which the safety of the device cannot be guaranteed. They are not meant to imply that the devices should be operated at these limits. The table of "Electrical Characteristics" specifies conditions of device operation.

Note 2: Min/max ratings are based on product characterization and simulation. Individual parameters are tested as noted. Outgoing quality levels are determined from tested parameters.

Note 3: J-level spec. is 100% tested at +25°C.

Note 4: V_{LL} and all V_{EE} supply pins are bypassed with 0.01 μF ceramic capacitor.

Note 5: Bit error rate less than 10^{-9} over 50% of the bit cell interval.

Note 6: Measured using a pseudo-random ($2^{23}-1$ pattern) binary sequence with all other channels active with an uncorrelated signal.

Note 7: Spread in propagation delays for all input/output combinations.

Note 8: Measured between the 20% and 80% levels of the waveform.

Note 9: Difference in propagation delay for output low-to-high vs. output high-to-low transition.

Note 10: Refer to the *Configuration Timing Diagram*.

Note 11: Refer to the *Reset Timing Diagram*.

Note 12: The bias current for high speed data input depends on the number of data outputs that are selecting that input.

Note 13: The V_{CC} supply current is a function of the number of active data outputs. $I_{VCC} = 18 \cdot N + 7$ mA where N is an integer from 0 to 8.

Note 14: $I_{VEE} = I_{VCC} + I_{VLL}$.

Typical Performance Characteristics

Jitter vs. Data Rate

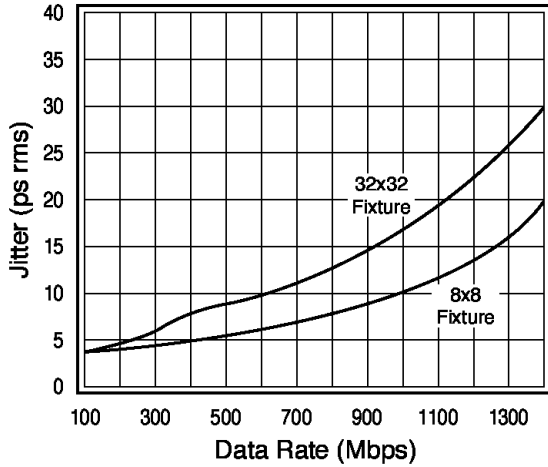

10008803

Percent Eye Opening vs. Data Rate

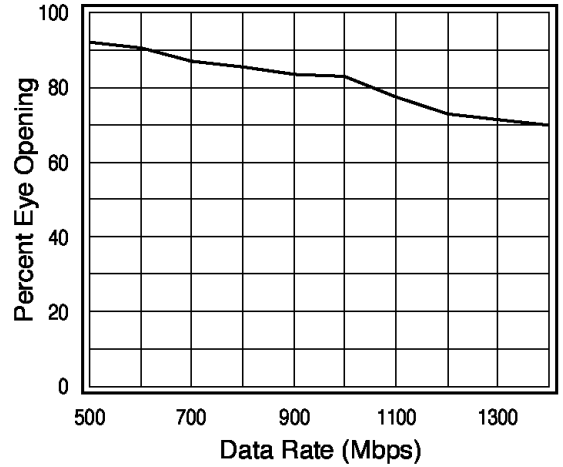

10008804

Output Current vs. Supply Voltage

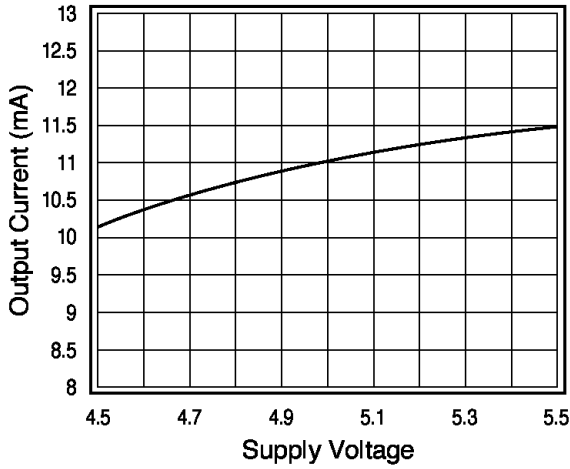

10008805

Output Current vs. Temperature

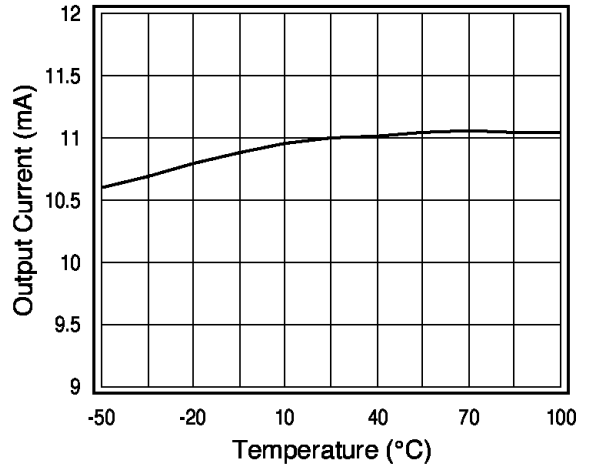

10008806

Prop. Delay vs. Temperature

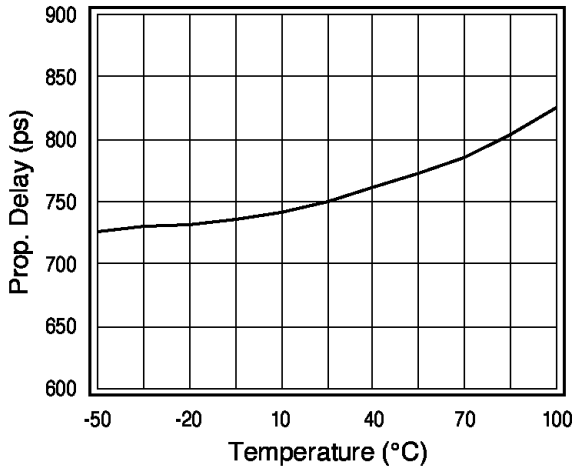

10008807

Total Supply Current vs. Temperature

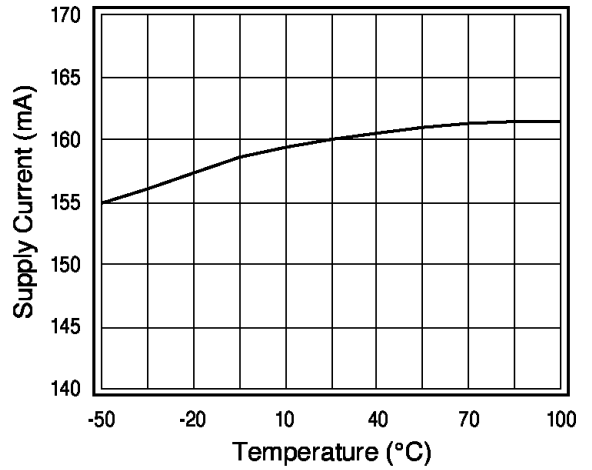

10008808

Connection Diagram

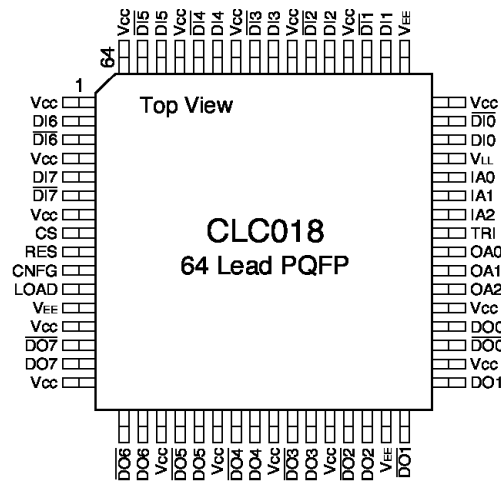

10008809

Order Number CLC018AJVJQ
See NS Package Number VJQ64A

Pin Descriptions

POWER PINS

V_{CC} is the most positive rail for the data path. When the data levels are ECL compatible, then V_{CC} should be connected to GND. For PECL data (+5V referenced ECL), V_{CC} is connected to the +5V supply. Please refer to the device operation section in this datasheet for recommendations on the bypassing and ground/power plane requirements of this device.

V_{EE} is the most negative rail for the data path. When the data levels are ECL compatible, then V_{EE} is connected to a -5.2V power supply. For PECL data (+5V referenced ECL), V_{EE} is connected to GND.

V_{LL} is the logic-level power supply. If the control signals are referenced to +5V, V_{LL} is connected to a +5V supply. If control signals are ECL compatible, V_{LL} is connected to GND.

DATA INPUT PINS

DI0 and $\overline{DI0}$ through DI7 and $\overline{DI7}$ are the data input pins to the CLC018. Depending upon how the Power pins are connected (please refer to the Power Pin section above) the data may be either differential ECL, or differential PECL. To drive the CLC018 inputs with a single-ended signal, please refer to the section "Using Single-Ended Data" in the OPERATION section of this datasheet.

DATA OUTPUT PINS

DO0 and $\overline{DO0}$ through DO7 and $\overline{DO7}$ are the data output pins of the CLC018. The CLC018 outputs are differential current outputs which can be converted to ECL or PECL compatible outputs through the use of load resistors. Please refer to the "Output Interfacing" paragraph in the OPERATION section of this datasheet for more details.

CONTROL PINS

IA2, IA1 and IA0 are the three bit input selection address bus. The input port to be addressed is placed on this bus. IA2 is the Most Significant Bit (MSB). If input port 6 is to be

addressed, IA2, IA1, IA0 should have 1, 1, 0 asserted on them. The IA bus should be driven with CMOS levels, if V_{LL} is +5V. These levels are thus +5V referenced (standard CMOS). If V_{LL} is connected to GND, the input levels are referenced to the -5V and GND supplies.

OA2, OA1 and OA0 are the output selection address bus. The output port selected by the OA bus is connected to the input port selected on the IA bus when the data is loaded into the configuration registers. OA2 is the MSB. If OA2, OA1, OA0 are set to 0, 0, 1; then output port 1 will be selected.

CS is an active-high chip select input. When CS is high, the RES, LOAD, and CNFG pins will be enabled.

LOAD is the latch control for the LOAD register. When LOAD is high, the load register is transparent. Outputs follow the state of the IA bus, and are presented to the inputs of the Configuration register selected by the OA bus. When LOAD is low, the outputs of the Load register are latched.

RES is the reset control of the configuration and load registers. A high-going pulse on the RES pin programs the switch matrix to one of two possible states: with TRI low, all outputs are connected to input #0; with TRI high, all outputs are put in TRI-STATE condition.

TRI will program the selected output to be in a high impedance or TRI-STATE condition. To place an output in TRI-STATE, assert a logic-high level on the TRI input when the desired input and output addresses are asserted on the respective address inputs and strobe the LOAD input as depicted in the "Configuration Truth Table". To enable an output, assert a logic-low level on the TRI input together with the appropriate addresses and strobe the LOAD input as previously described.

CNFG is the configuration register latch control. When CNFG is high the Configuration register is made transparent, and the switch matrix is set to the state loaded into the Load registers. When CNFG is low, the state of the switch matrix is latched.

Timing Diagrams

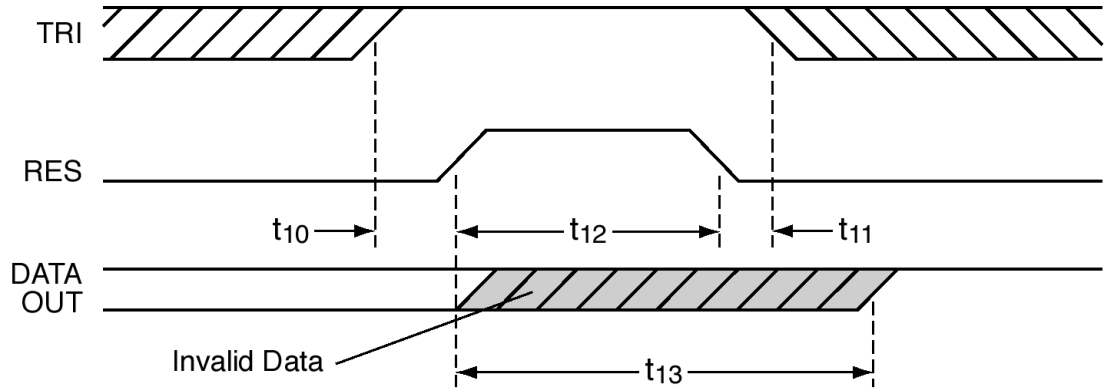

10008810

FIGURE 1. Timing Diagram — TRI-STATE Reset

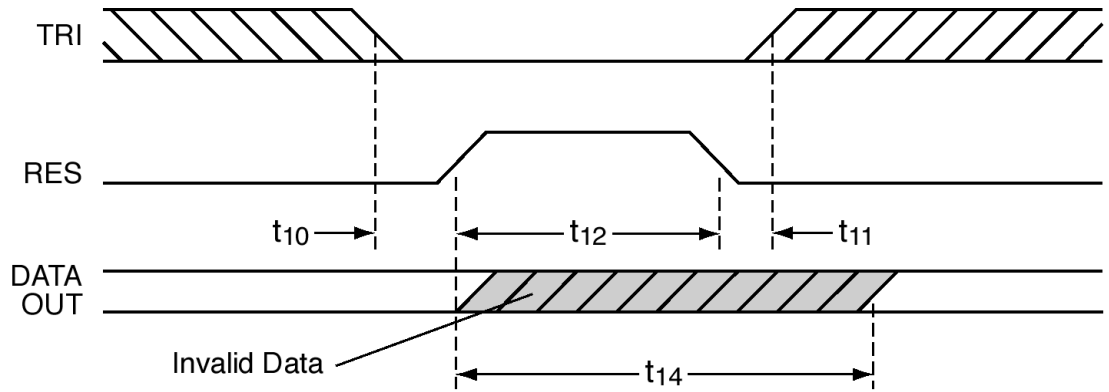

10008811

FIGURE 2. Timing Diagram — "Broadcast Reset"

Timing Diagrams (Continued)

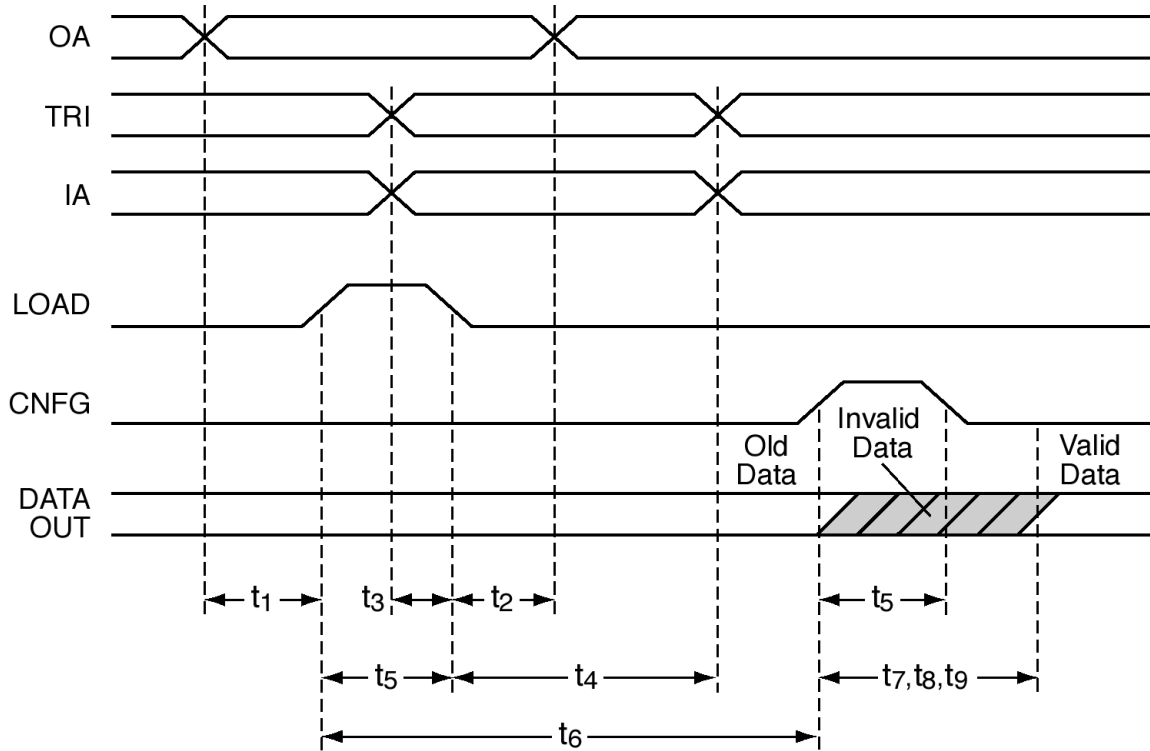

10008812

FIGURE 3. Timing Diagram—Switch Configuration

Operation

INPUT INTERFACING

The inputs to the CLC018 are high impedance differential inputs (see the equivalent input circuit in Figure 4). The CLC018 can be operated with either ECL or PECL (+5V referenced ECL), depending upon the power supply connections. The inputs are differential and must both be within the range of $V_{CC} - 2V$ to $V_{CC} + 0.4V$ in order to function properly.

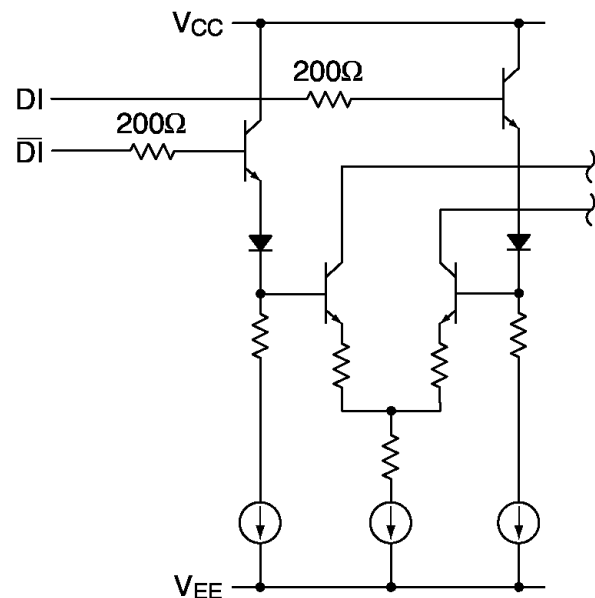

10008813

FIGURE 4. Equivalent Input Circuit

Operation (Continued)

SINGLE ENDED INPUTS

Differential inputs are the preferred method of providing data to the CLC018, however, there are times when the only signal available is single ended. To use the CLC018 with a single ended input, the unused input pin needs to be biased at a point higher than the low logic level, and lower than the high logic level. For best noise performance, the middle of the range is best. For ECL signals this point is about 2 diode drops below ground. It is possible to bias the unused input with a low-pass filtered version of the data, as shown in *Figure 5*. In some coding schemes there are pathological patterns that result in long sequences with no data transitions. During these patterns, the bias on the unused input will drift towards the other input reducing the noise immunity which makes this scheme undesirable. The most robust solution for single ended inputs is to place a comparator with hysteresis in front of the CLC018. Such a part is the MC10E1652. See *Figure 6* for an example of how to hook this up.

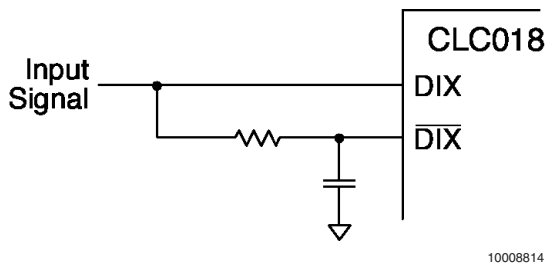

FIGURE 5. Single Ended Input to CLC018

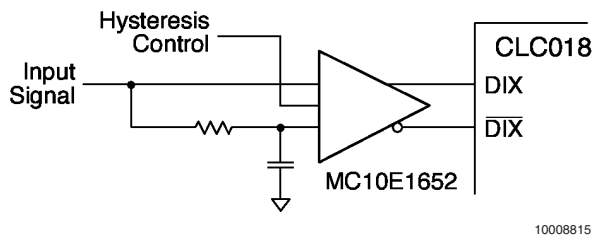

FIGURE 6. Single Ended Input to CLC018

OUTPUT INTERFACING

The outputs of the CLC018 are differential, current source outputs. They can be converted to ECL compatible levels with the use of resistive loads as shown in *Figure 7*. The output swings will have a similar temperature coefficient to 10KECL if a 1N4148 diode is used to set V_{OH} . For most commercial temperature range applications, a 75Ω resistor can be used as shown in *Figure 8*. Many circuits with differential inputs, such as the CLC016 Data Retimer With Automatic Rate Selection, do not require true ECL levels, so the load resistors can be connected directly to the positive rail as shown in *Figure 9*.

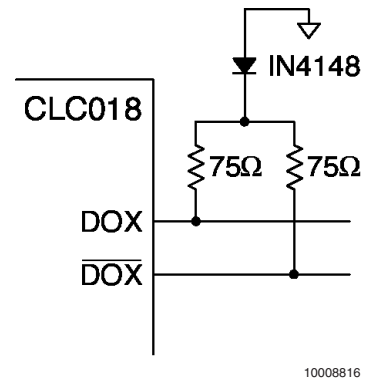

FIGURE 7. Generating 10k ECL Outputs

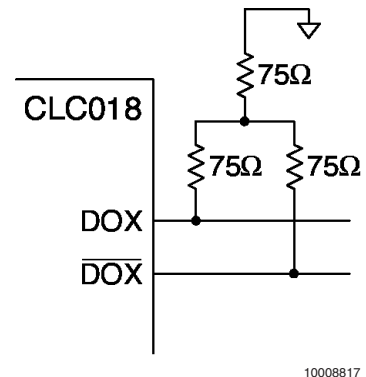

FIGURE 8. Generating ECL Outputs

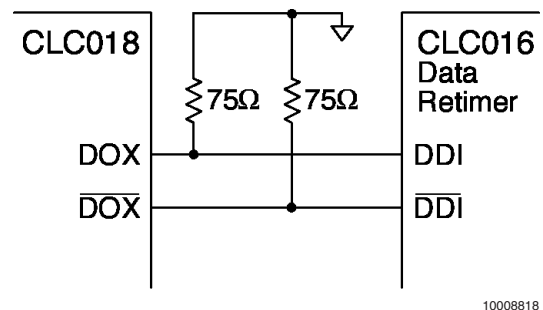

FIGURE 9. Connecting the CLC018 to the CLC016

OUTPUT SIGNAL QUALITY

The output signal eye pattern shown in *Figure 10* was acquired using an Agilent 86100A scope and 86112A plug in along with a TEK P6330 3GHz differential probe. The differential signal was probed across the output pins of the CLC018. 75Ω pull up resistor were used as shown in *Figure 9*. A PRBS23 pattern was driven through the part, and the resulting eye pattern is shown in *Figure 10*. The eye pattern is affected by the HF roll-off of the probe which degrades the output transition time and affects jitter. Even with this loading the CLC018 provides excellent signal quality and low jitter at 1.485 Gbps. Note 150 ps/div and 250 mV/div

Operation (Continued)

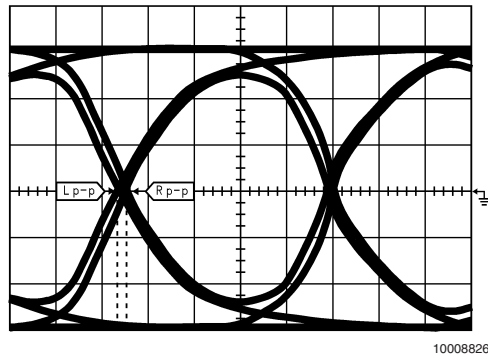

FIGURE 10. 1.485 Gbps Eye Pattern

POWER SUPPLIES, GROUNDING AND BYPASSING

The CLC018 uses separate power supplies for control and data circuitry. Data circuitry is supplied via V_{CC} and control circuitry via V_{LL} . Supply connection V_{EE} , the negative-most supply, is the common return for both. Connection details for the different powering modes is shown in *Table 1*.

Internal and external capacitances, normal and parasitic, must be charged and discharged with changes in output voltage. Charging current depends upon the size of these capacitances and the rate of change of voltage. At the fast transition times of the CLC016, small amounts of stray capacitance at outputs can produce large output and supply transient currents. Controlling transient currents requires particular attention to minimizing stray capacitances and to providing effective bypassing in the design. Good and effective bypassing consisting of 0.01 μF to 0.1 μF monolithic ceramic and 4.7 μF to 10 μF , 35V tantalum capacitors. These capacitors should be placed as close to power pins as practical and tightly connected to the power plane sandwich using multiple vias. Needless to say, multilayer board technology should be employed for the CLC018 and similar high-frequency-capability devices.

CONFIGURING THE SWITCH

The CLC018 can be configured so that any output may be independently connected to any input and any input be connected to any or all outputs. Each output may be independently enabled or placed in a high-impedance state.

Data controlling the switch matrix and output mode are stored in two ranks of eight, 4-bit registers, one register per output. The three most-significant bits in each register identify the input to be connected to that output. The least-

significant bit controls whether the output is active or TRI-STATE. A particular register in the first rank, the LOAD REGISTERS, is selected by a 3-bit word placed on the output address (OA) bus. Data to be written into the load register, consisting of the 3-bit address of the input to be connected to that output and the output-enable control bit, are placed on the input address (IA) bus. Input data is stored in the load registers at the low-to-high transition of the LOAD input pin with chip-select (CS) high-true. The contents of the load registers are transferred to the second rank of CONFIGURATION REGISTERS at the low-to-high transition of the CNFG input signal (with CS high). This causes the state of the entire switch matrix to be set to the selected configuration.

The entire crosspoint may be placed in an initializing state, with all outputs connected to input-0 and with all outputs either enabled or TRI-STATE. To do so, hold TRI low to make outputs active, or high to place outputs in TRI-STATE, and apply a high-going pulse to the RES input pin (with CS high). In summary, outputs are configured by:

- first placing the 3-bit address of that output on the OA bus together with
- the 3-bit address of the input to be connected to that output on the IA bus,
- the output-enable (TRI-STATE) control bit for that output on the IA bus,
- making chip-select (CS) true, and then
- providing a high-going pulse to the LOAD input pin.
- Repeat these four steps for each output to be configured.

The entire crosspoint matrix may now be configured with the data held in the load registers. To implement the configuration, apply a high-going pulse to the CNFG input pin. The contents of the load registers are transferred to the configuration registers and the new configuration of all crosspoints is effected.

The CLC018 Configuration Truth Table is shown at the end of the datasheet.

EXPANDING THE SWITCH SIZE

The CLC018 was designed for easy expansion to larger array sizes without paying a significant penalty in either speed or power. The power dissipation of the expanded array will be dominated by the number of active outputs, therefore power will increase linearly with the array size even though the number of components required increases as the square of the array size. As an example, a single CLC018 can be used for an 8x8 array, and it will dissipate about 0.85W. A 32 x 32 array will require 16 CLC018s and will consume only about 4W.

Operation (Continued)

TABLE 1. Interfacing of the Power Supplies and Bypass Capacitors

Supply Operation	Single -5V	Single +5V	Dual ±5V
I/O Data Level	ECL	PECL	ECL
Control Signal Low/High	-5V/GND	GND/+5V	GND/+5V
Connection			
Key Information	<ol style="list-style-type: none"> 1. Bypass each V_{EE} supply with a $0.01\ \mu\text{F}$ capacitor. 2. Connect V_{CC} and V_{LL} to the ground plane. 3. A power plane isn't required for V_{EE} but can be used. 	<ol style="list-style-type: none"> 1. Bypass each V_{CC} supply with a $0.01\ \mu\text{F}$ capacitor. 2. Bypass the V_{LL} supply with a $0.01\ \mu\text{F}$. 3. Connect V_{EE} to the ground plane. 4. Use a +5V power plane for V_{CC}. 	<ol style="list-style-type: none"> 1. Bypass each V_{EE} supply with a $0.01\ \mu\text{F}$ capacitor. 2. Bypass the V_{LL} supply with a $0.01\ \mu\text{F}$. 3. Connect V_{CC} to the ground plane. 4. A power plane isn't required for +5V (V_{LL}) or -5V (V_{EE}) supplies. but can be used.

EXPANDING THE NUMBER OF OUTPUT PORTS

To expand the number of output ports in a switch array, the inputs of multiple CLC018s are connected in parallel. The bus used to connect the input ports should be a controlled impedance transmission line as shown in *Figure 11*. To

control the switch array, the IA, OA and TRI busses are all connected in parallel and a decoder is used to assert high the CS of the CLC018 that is to be addressed. This is also shown in *Figure 11*.

Operation (Continued)

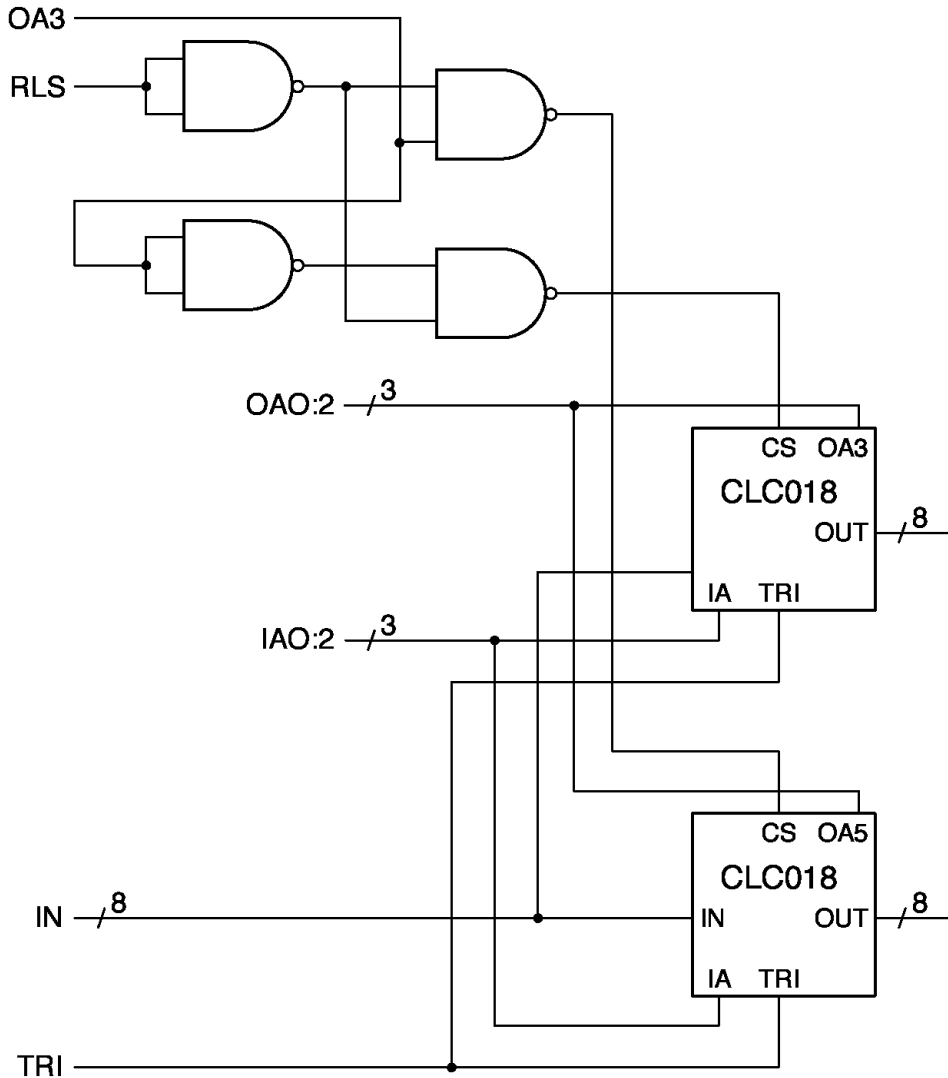

10008820

FIGURE 11. 8 x 16 Crosspoint Example

EXPANDING THE NUMBER OF INPUT PORTS

Expanding the number of inputs in a switch array is accomplished by wire-ORing the outputs together, and TRI-STATEing the outputs of the CLC018s that do not have their inputs selected. The output bus should be a controlled impedance transmission line with proper termination. This is shown in *Figure 12*. The circuit uses a 1-of-2 decoder with complemented outputs to control the TRI pins of the CLC018s in the array. Thus, all CLC018s are programmed simultaneously, and all of them, except for the one with the selected input, are placed in the TRI-STATE mode.

EXPANDING BOTH INPUTS AND OUTPUTS

To increase both the number of inputs and outputs in an array, apply both the input port and output port expansion techniques simultaneously. In *Figure 13*, this is shown for the case of a 24 input by 32 output switch array. Note that both input and output busses need to be controlled impedance transmission lines. The CS pins for rows of CLC018s are connected together and become the row select inputs, whereas the TRI pins are connected together for the columns of CLC018s and become the column select pins.

Operation (Continued)

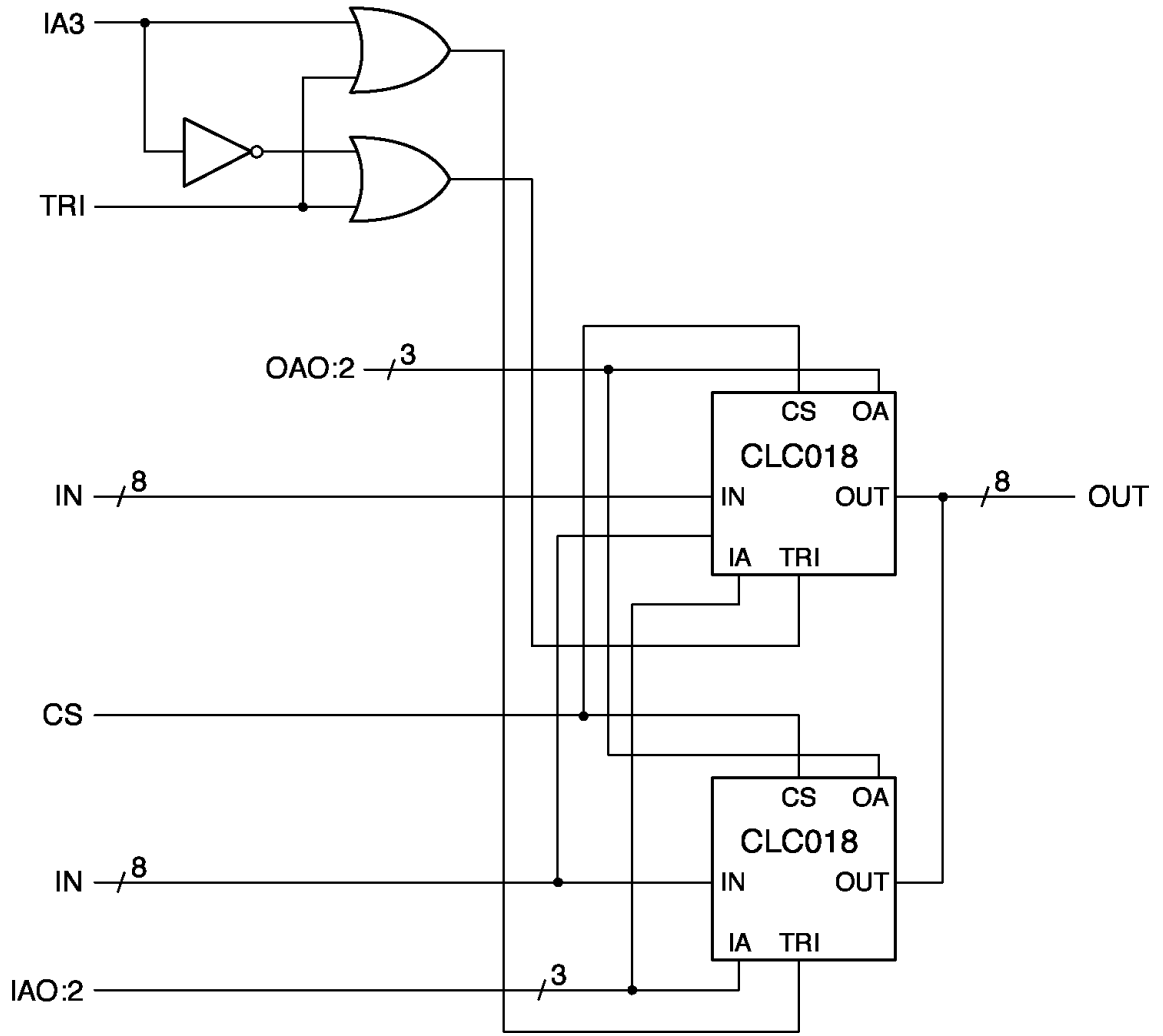

10008821

FIGURE 12. Expanded Input Ports

Operation (Continued)

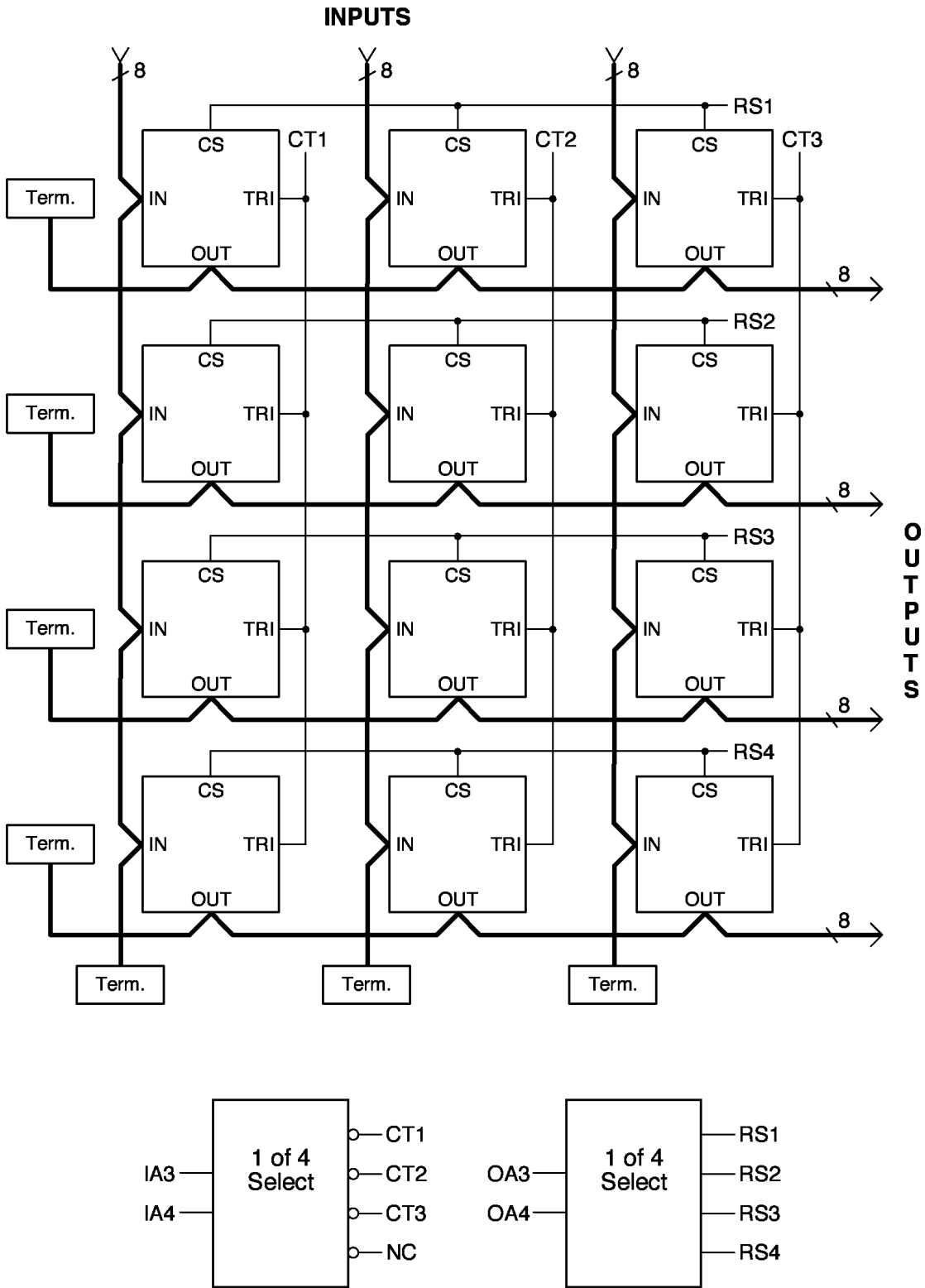

10008822

FIGURE 13. 24 x 32 Output Switch Array

Operation (Continued)

CALCULATING THE POWER DISSIPATION IN AN EXPANDED ARRAY

The CLC016 dissipates about 100 mW per active output plus about 50 mW quiescent power. With all outputs active, this is about 850 mW. In an expanded array, all devices will dissipate quiescent power, but only those devices with active outputs will dissipate the 100 mW/output. So, an N-by-M device array (an 8xN-input-by-8xM-output switch) with all outputs active will dissipate $N \times M \times 50 \text{ mW} + 8 \times M \times 100 \text{ mW}$. A 32-input x 32-output (4 x 4 device) switch array dissipates $4 \times 4 \times 50 \text{ mW} + 8 \times 4 \times 100 \text{ mW} = 4 \text{ W}$.

CONTROLLED IMPEDANCE TRANSMISSION LINES AND OTHER LAYOUT TECHNIQUES

All transmission lines whose length is greater than $\frac{1}{4}$ wavelength of the highest frequencies present in the transmitted signal require proper attention to impedance control to avoid distortion of the signal. Digital signals are especially susceptible to distortion due to poorly controlled line characteristics and reflections. With its 250 ps output transitions, which imply a bandwidth of 4 GHz or more, transmission lines driven by the CLC018 must be carefully designed and correctly terminated. Either microstrip line, which resides on the outer surfaces of a printed circuit board and paired with an image ground plane, or stripline, which is sandwiched in an inner layer between image ground planes, may be used in CLC018 designs. With either line type, it is important to maintain a uniform characteristic impedance over the entire extent of the transmission line system. Likewise, the receiving end of these lines must be terminated in a resistance equal to the characteristic impedance to preserve signal fidelity. *Figure 14* shows representative methods of interfacing to and from the CLC018.

Often, when voltage-mode drivers, such as ECL, with low output impedance (also called equivalent generator resis-

tance) are used to drive bus networks, a series resistor connects the output of the amplifier to the transmission line. This resistor serves both as a termination for any signals travelling toward the source- end of the line and as the series leg of a voltage divider (with the transmission line as the shunt leg) to reduce the transmitted signal level. This resistor's correct value is $Z_O - R_{OUT}$. However, a value equal to Z_O may be used successfully in most situations. The receiving end of the line is terminated in a resistance equal to the value of Z_O of the receiving end of the line. A resistance equal to the line's Z_O works in most situations. In cases where the bus is heavily loaded, the receiving end termination's value may need to be reduced to the loaded- Z_O of the line. (Please see the material on distributed loading effects on line characteristics in the *Fairchild F100K ECL 300 Series Databook and Design Guide*).

Current-mode drivers, with their high equivalent generator resistance, when used as bus drivers require a resistance equal to Z_O at each end of the bus to either power or ground as appropriate for the design.

A detailed discussion of digital transmission line design techniques is beyond the scope of this data sheet, but many good references are available from National Semiconductor and others. Extensive material is available in the *National Interface Databook*, the *Fairchild F100K ECL 300 Series Databook and Design Guide* and the *Motorola MECL System Design Handbook*.

Especially useful is the National Semiconductor *Transmission Line RAPIDESIGNER*® Sliderule and user manual AN-905. The RAPIDESIGNER is available by calling the National Semiconductor Customer Response Center in your area and asking for either Literature Number 633200-001 (ISO Metric units) or 633201-001 (English units). The User Manual for both versions is Literature Number 100905-002 and is available on our WEB Site at <http://www.national.com> as AN-905.

Operation (Continued)

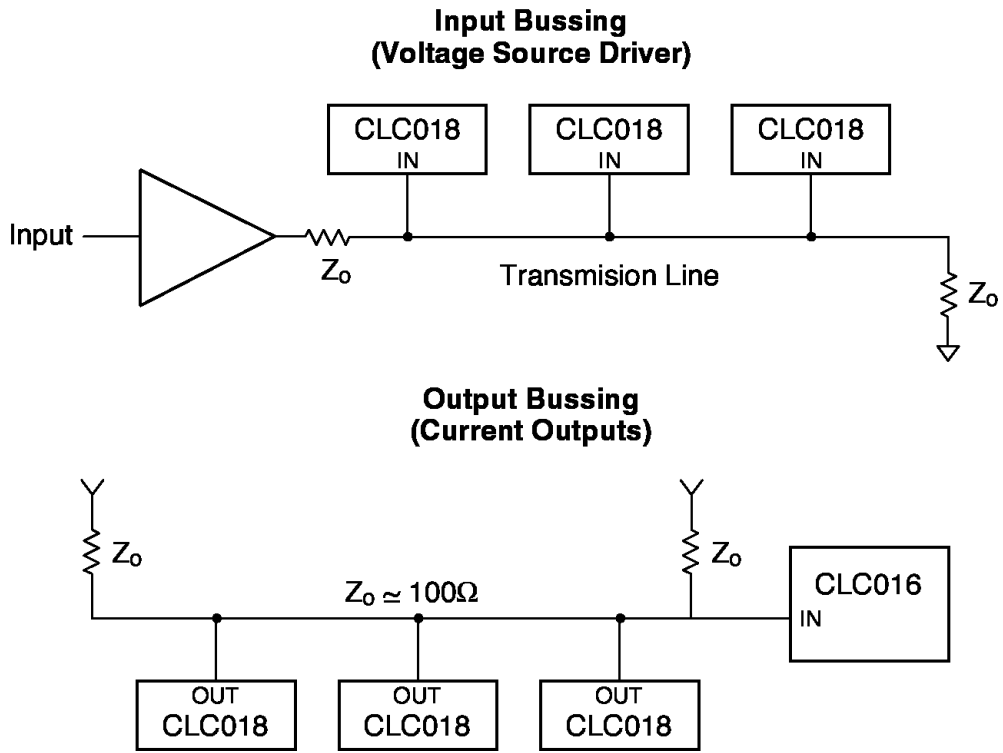

10008823

FIGURE 14. Input/Output Bussing

Configuration Truth Table											
IA2	IA1	IA0	OA2	OA1	OA0	TRI	RES	LOAD	CNFG	CS	Condition of Device
X	X	X	X	X	X	X	X	X	X	0	NO CHANGE
X	X	X	X	X	X	0	⌋	X	X	1	Load I/P 0 to All O/Ps
X	X	X	X	X	X	1	⌋	X	X	1	TRI-STATE All O/P 0
X	X	X	0	0	0	1	0	⌋	0	1	TRI-STATE O/P 0
X	X	X	0	0	1	1	0	⌋	0	1	TRI-STATE O/P 1
X	X	X	0	1	0	1	0	⌋	0	1	TRI-STATE O/P 2
X	X	X	C	B	A	1	0	⌋	0	1	TRI-STATE O/P CBA
•	•	•	•	•	•	•	•	•	•	•	•
R	Q	P	C	B	A	0	0	⌋	0	1	Load I/P PQR to O/P CBA and Enable O/P CBA
•	•	•	•	•	•	•	•	•	•	•	•
0	0	0	0	0	0	0	0	⌋	0	1	Load I/P 0 to O/P 0
0	0	0	0	0	1	0	0	⌋	0	1	Load I/P 0 to O/P 1
0	0	0	0	1	0	0	0	⌋	0	1	Load I/P 0 to O/P 2
0	0	0	0	1	1	0	0	⌋	0	1	Load I/P 0 to O/P 3
0	0	0	1	0	0	0	0	⌋	0	1	Load I/P 0 to O/P 4
0	0	0	1	0	1	0	0	⌋	0	1	Load I/P 0 to O/P 5
0	0	0	1	1	0	0	0	⌋	0	1	Load I/P 0 to O/P 6
0	0	0	1	1	1	0	0	⌋	0	1	Load I/P 0 to O/P 7
0	0	1	0	0	0	0	0	⌋	0	1	Load I/P 1 to O/P 0
0	0	1	0	0	1	0	0	⌋	0	1	Load I/P 1 to O/P 1
0	0	1	0	1	0	0	0	⌋	0	1	Load I/P 1 to O/P 2
0	0	1	0	1	1	0	0	⌋	0	1	Load I/P 1 to O/P 3
•	•	•	•	•	•	•	•	•	•	•	•
0	0	1	1	1	1	0	0	⌋	0	1	Load I/P 1 to O/P 7
•	•	•	•	•	•	•	•	•	•	•	•
1	1	1	1	1	0	0	0	⌋	0	1	Load I/P 7 to O/P 6
1	1	1	1	1	1	0	0	⌋	0	1	Load I/P 7 to O/P 7
X	X	X	X	X	X	X	0	0	⌋	1	Activate New Configuration

Physical Dimensions inches (millimeters) unless otherwise noted

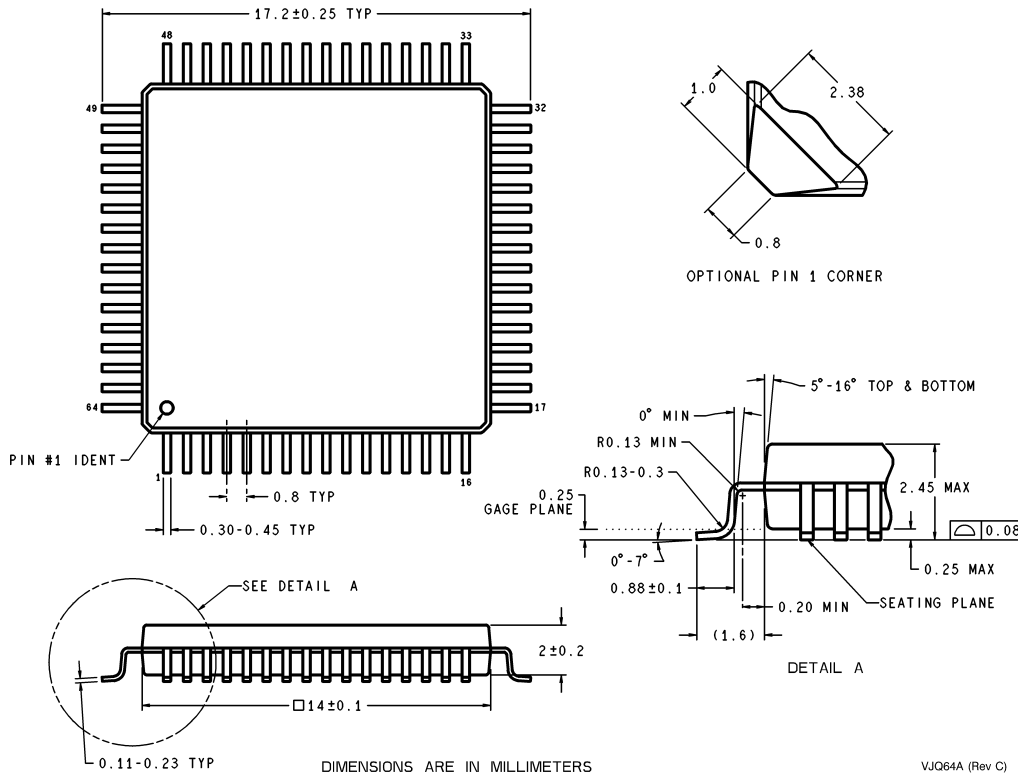

64-Lead PQFP
Order Number CLC018AJVJQ
NS Package Number VJQ64A

National does not assume any responsibility for use of any circuitry described, no circuit patent licenses are implied and National reserves the right at any time without notice to change said circuitry and specifications.
 For the most current product information visit us at www.national.com.

LIFE SUPPORT POLICY

NATIONAL'S PRODUCTS ARE NOT AUTHORIZED FOR USE AS CRITICAL COMPONENTS IN LIFE SUPPORT DEVICES OR SYSTEMS WITHOUT THE EXPRESS WRITTEN APPROVAL OF THE PRESIDENT AND GENERAL COUNSEL OF NATIONAL SEMICONDUCTOR CORPORATION. As used herein:

1. Life support devices or systems are devices or systems which, (a) are intended for surgical implant into the body, or (b) support or sustain life, and whose failure to perform when properly used in accordance with instructions for use provided in the labeling, can be reasonably expected to result in a significant injury to the user.
2. A critical component is any component of a life support device or system whose failure to perform can be reasonably expected to cause the failure of the life support device or system, or to affect its safety or effectiveness.

BANNED SUBSTANCE COMPLIANCE

National Semiconductor follows the provisions of the Product Stewardship Guide for Customers (CSP-9-111C2) and Banned Substances and Materials of Interest Specification (CSP-9-111S2) for regulatory environmental compliance. Details may be found at: www.national.com/quality/green.

Lead free products are RoHS compliant.



National Semiconductor
Americas Customer Support Center
 Email: new.feedback@nsc.com
 Tel: 1-800-272-9959

National Semiconductor
Europe Customer Support Center
 Fax: +49 (0) 180-530 85 86
 Email: europe.support@nsc.com
 Deutsch Tel: +49 (0) 69 9508 6208
 English Tel: +44 (0) 870 24 0 2171
 Français Tel: +33 (0) 1 41 91 8790

National Semiconductor
Asia Pacific Customer Support Center
 Email: ap.support@nsc.com

National Semiconductor
Japan Customer Support Center
 Fax: 81-3-5639-7507
 Email: jpn.feedback@nsc.com
 Tel: 81-3-5639-7560